



SEPRO FINE INCINERATOR BOTTOM ASH TREATMENT PLANT

APPLICATIONS

- Precious and base metals recovery from fine incinerator bottom ash

KEY ADVANTAGES

- Pioneering fine IBA treatment (0 – 2 mm) with industry standard Falcon centrifugal concentrators optimised for IBA
- Possible adaptation to dry or wet IBA treatment plants
- Recovery of precious metals (Au, Ag, PGM) and heavy metals (Cu, Pb, Zn)
- High grade concentrates
- Low concentrate mass
- Concentrates for direct sale or further upgrading
- Minimized heavy metals content in rejects
- Fresh IBA and aged IBA can be treated by wet process
- Compact and modular plant design, pre-assembled
- 0 – 2 mm feed particle size
- Available in 10 t/h and 20 t/h fines capacity per module
- Feed protection screen removes oversize
- Low intensity magnetic separator produces Fe product
- Falcon centrifugal concentrator produces precious metal concentrate
- Full automation
- Built to European or North American standards

DIMENSIONS

- 6.3 m x 2.7 m x 6.3 m (LxWxH)*

*Dimensions depending on configuration

Modern **Incinerator Bottom Ash (IBA)** processing facilities are targeting the recovery of metals from coarse (+2 mm or coarser) fractions, with Ferrous, Aluminum, Copper, Stainless Steel and Zinc being the main contributors. Valuable metals in the fine particle sizes (0 – 2 mm) were previously considered unrecoverable.

Sepro's pioneering **Fine Slag Treatment Plant** module can now add a precious metals dimension. With today's first world throw-away societies, increasing amounts of precious metals are found in fine IBA, tracing back to mainly electronics and jewelry. Fine IBA contains Gold (0.3 – 1 ppm), Silver (5 – 20 ppm) as well as Platinum group metals (in minor amounts). At the same time, the plant helps meeting environmental targets in terms of minimized heavy metals / leachable contaminants in the rejected bottom ash.

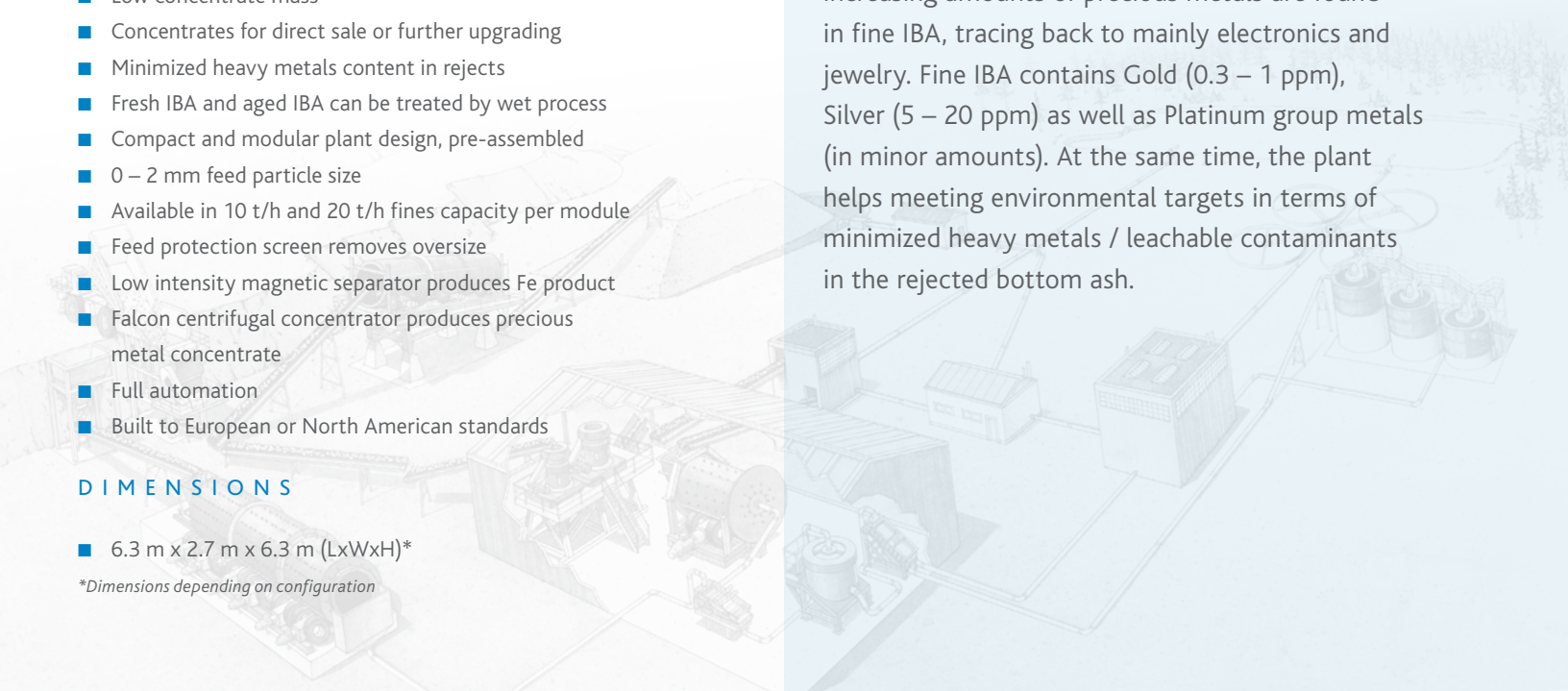

SEPRO FINE INCINERATOR BOTTOM ASH TREATMENT PLANT

PLANT SCHEMATIC

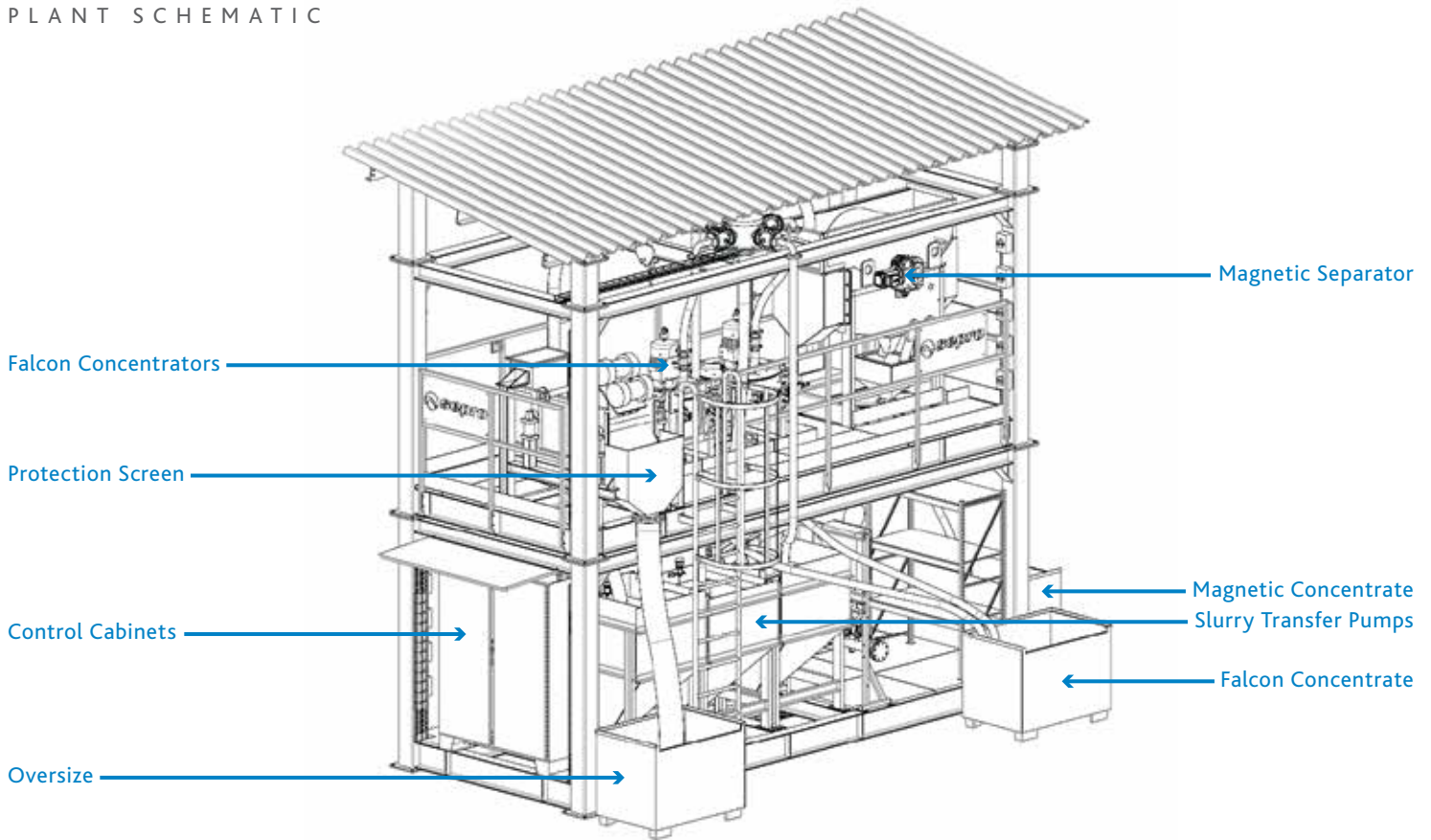

FALCON CONCENTRATOR SCHEMATIC

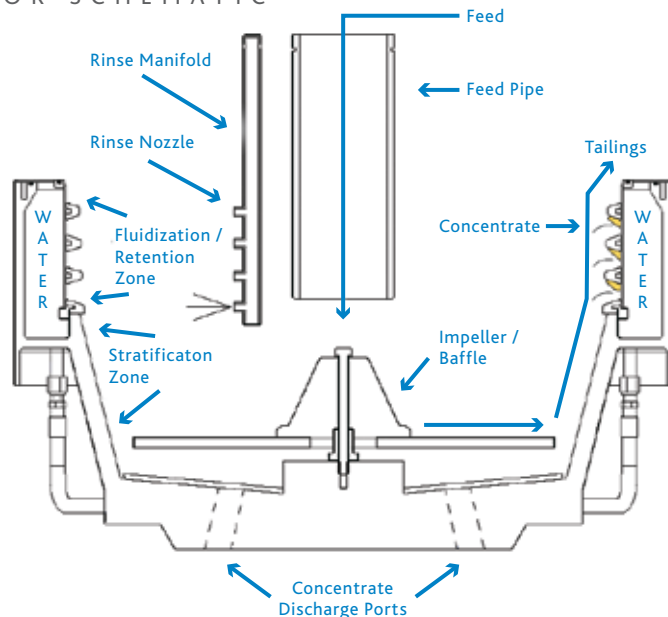

Sepro Mineral Systems Corp.
 9850 201 Street, Langley, British Columbia, Canada V1M 4A3
 Office: +[1] 604.888.5568 • Fax: +[1] 604.888.5521 • Toll free: +[1] 800.990.5568 North America
 sepro@seprosystems.com • www.seprosystems.com